

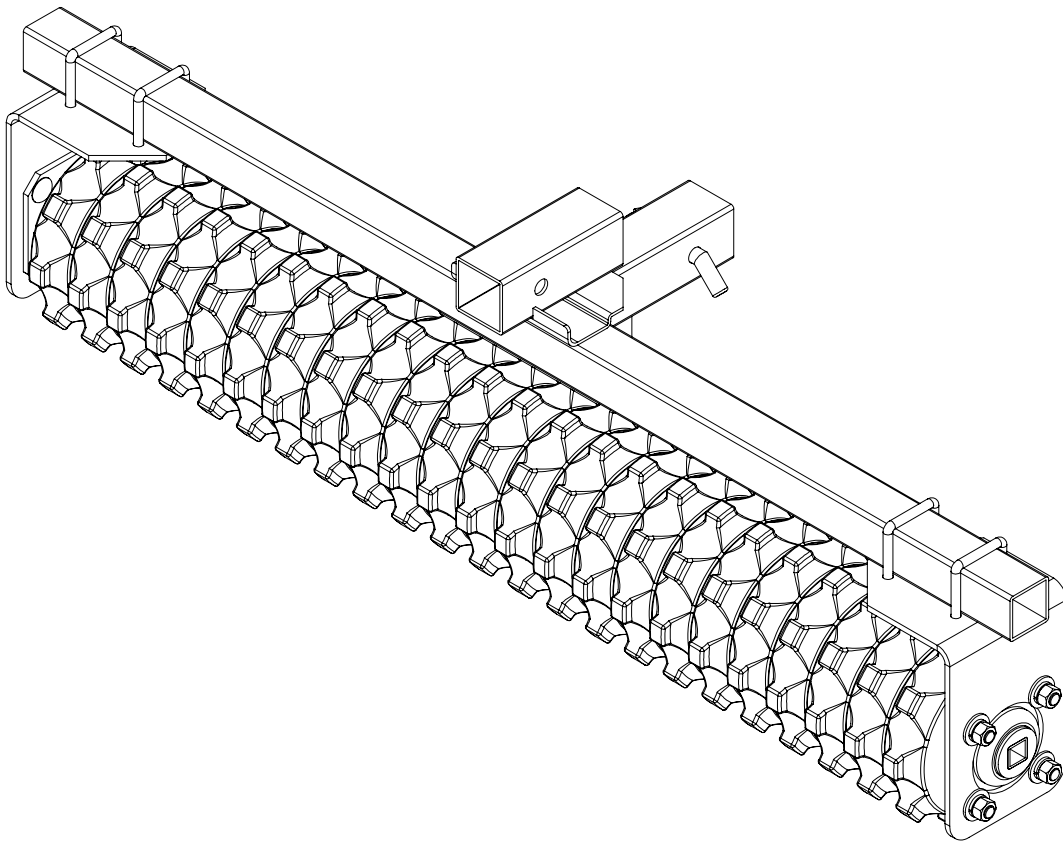

PO Box 315, Buffalo MN 55313
www.impactimplements.com - info@impactimplements.com

Cultipacker



BEFORE YOU BEGIN:

- Please read and understand all instructions.
- Verify all parts and tools are accounted for.
- To ensure a satisfactory installation, follow all steps correctly and in the sequence described.
- All directions referring to right and left are when the rider is sitting on the machine

INSTALLATION NOTES: TOOLS REQUIRED:

- Basic Hand Wrench and Socket Set
- Plastic Cutting Tool - for opening packaging.

DESCRIPTION: Cultipacker
UPC: 7347
ITEM #: 7347

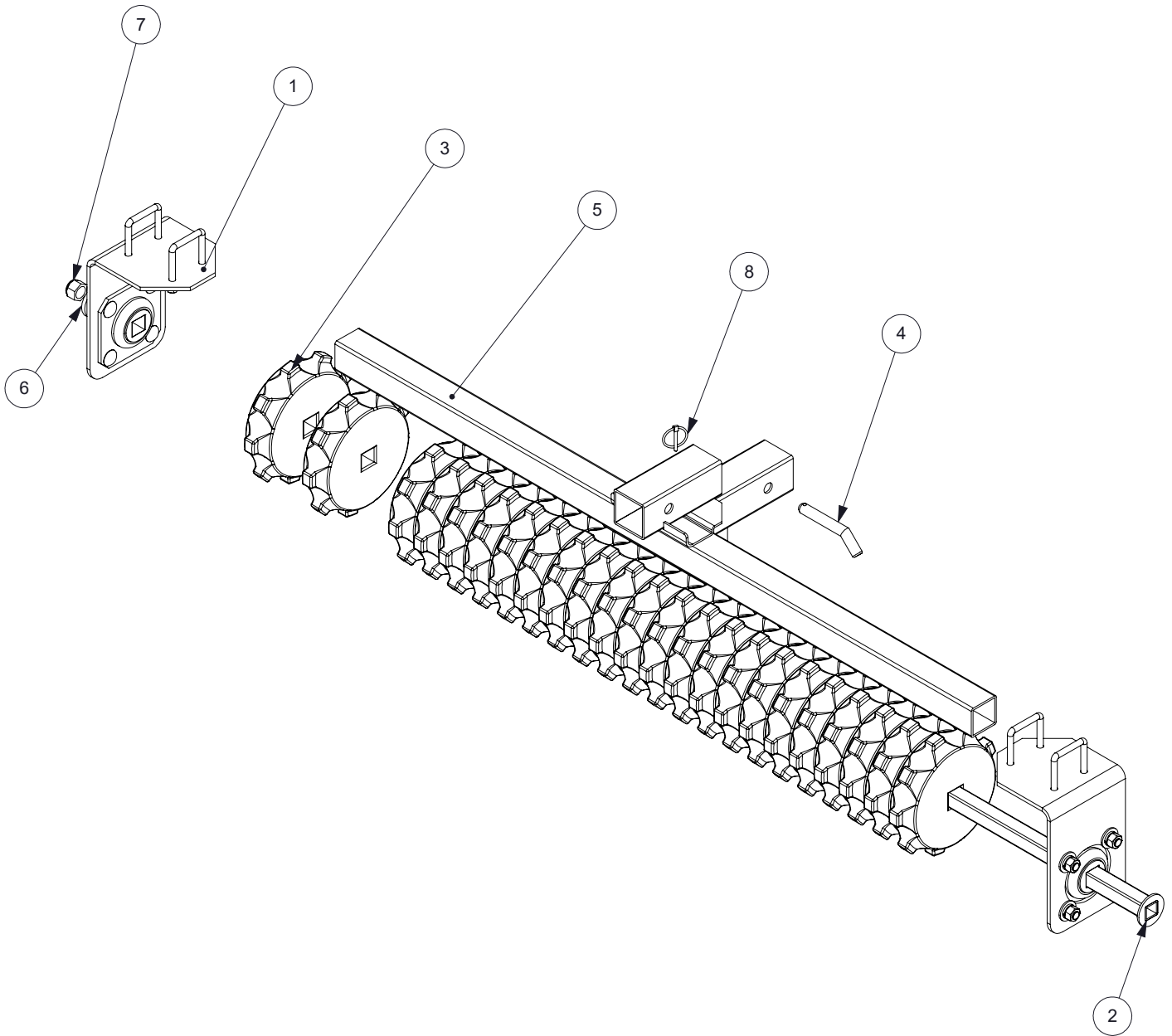

ITEM NO.	Description	QTY.
1	Bearing Carrier Assembly	2
2	Axle	1
3	Cultipactor Wheel	23
4	5/8" Bent Hitch Pin with Keeper	1
5	Aerator Tool Bar	1
6	Axle Washer	1
7	3/4-10 Nylock Nut	1
8	5/32" x 1.40" Lynch Pin	1

DESCRIPTION: Cultipacker
 UPC: 7347
 ITEM #: 7347

ITEM NO.	Description	QTY.
1	Bearing Bracket	1
2	"U" Bolt 3/8-16 x 3.00"	2
3	Flange Bearing	1
4	.375" Flat Washer	4
5	.50" Flat Washer	4
6	.375" Lock Washer	4
7	.50" Lock Washer	4
8	3/8-16 Hex Nut	4
9	1/2-13 Hex Nut	4
10	1/2-13 x 1.25" Carriage Bolt	4

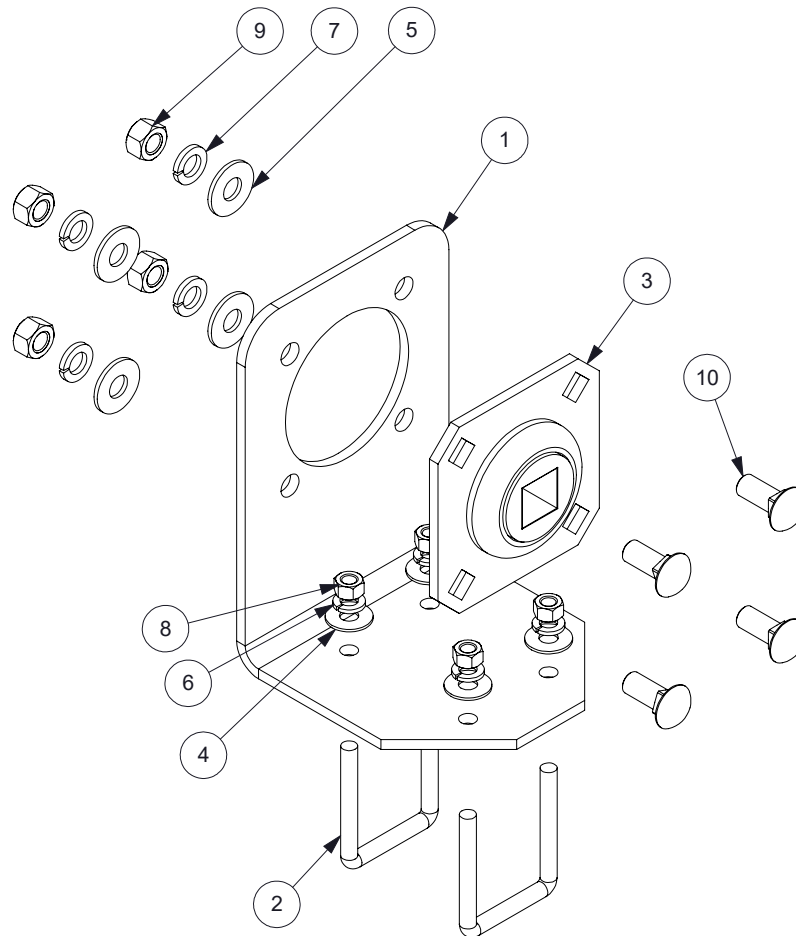

Qty (2) Sets of the above required.



Warranty and Limitations:

Impact Implements offers a limited one (1) year warranty for each new product against manufacturing defects in workmanship and materials. Exterior parts and finish (Paint, Powder Coating or Plating) are warranted against defects in original workmanship and materials. No warranty applies to exterior finish (Paint, Powder Coating or Plating) after initial use. The entire warranty is void if the product is used in commercial/industrial applications.

Wear Bars and Skid Feet or Pads, Rake Tines, Disc Plow disc's, Plow or S-Tines and Tires are considered wearable parts and are warranted against defects in original workmanship and materials. No warranty applies to wearable parts after initial use.

The obligation under this warranty, statutory or otherwise, is limited to the replacement or repair of such part as shall appear to the manufacturer, upon inspection of such part, to have been defective in material or workmanship. This warranty does not obligate Impact Implements to bear the cost of shipping charges in connection with the replacement or repair of defective parts, nor shall it apply to a product upon which repairs or alterations have been made, unless authorized by Impact Implements, or for equipment misused, neglected, or improperly installed.

WARRANTY CLAIMS:

If warranty parts are required, Impact Implements may send replacement parts free of charge to owners in the US and Canada. Other international locations will be required to pay for shipping charges on those parts. If in-person diagnosis is required, the owner is responsible for shipping charges connected to getting the product to Impact Implements. If the damage is covered under the warranty outlined above, Impact Implements will cover the cost of repair and return shipping charges. If it is not covered by the warranty, the repair charges and return shipping will be the responsibility of the owner. Typical service time would be three (3) weeks from receipt of returned item by Impact Implements to receipt of item to owner.

To the fullest extent permitted by applicable law, the following are hereby excluded and disclaimed:

- All warranties of fitness for a particular purpose
- All warranties of merchantability
- All claims for consequential or incidental damages

There are no warranties that extend beyond the description outlined above.

Some states do not allow the above exclusions or disclaimers in consumer transactions and as such this disclaimer/exclusion may not apply to your particular case. To the extent such warranties of applicability for a particular purpose or merchantability are deemed to apply to this product, they exist only for so long as the express limited warranty elsewhere set forth is in existence.

Impact Implements reserves the right to improve any product through changes in design or materials as desired without being obligated to incorporate such changes in products of previous manufacture. The stated warranty will not cover bills for service, labor or other expenses which have been incurred by the buyer. This warranty gives you specific legal rights and you may also have other legal rights which vary from state-to-state.

All warranty claims are based on initial invoice date. A copy of initial invoice will be required with any warranty request.

LIABILITY DISCLAIMER:

There are inherent risks involved in using any product, including but not limited to: serious physical injury and possible death. Impact Implements products are to be used by experienced adults over 18 years of age only. The Seller will not be held liable under any circumstance for incidental or consequential loss or damage or injury, due directly or indirectly to the use of Impact Implements products, including any malfunction from negligence or defect. The Seller makes no claims as to the suitability of Impact Implements products for any specific purpose or use. Buyer understands that the use of Impact Implements products can cause injury or death to themselves or others. The Buyer holds our company and its agents and affiliates harmless from any liability arising out of or relating to the use or ownership of any Impact Implements product. Buyer fully accepts responsibility and releases the seller for all and any personal injuries, fatal injuries, any losses, costs, and damages incurred as a result of Buyer or anyone else operating Impact Implements products. Once Buyer submits payment, this will serve as a Purchase Agreement thus releasing Seller of any and all responsibilities of items such as stated above. By purchasing a Impact Implements product, you acknowledge that you have read, understand and agree to the terms and conditions of this Agreement; you also represent that you are of legal age (age 18 years or older) to enter this Agreement and become bound by its terms.